

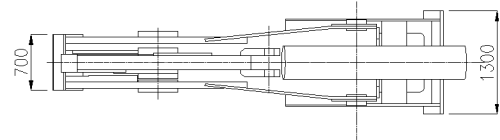

**Benefits for the customers**

- Mobile equipment: cost savings in scrap rehandling and transport
- Only one operator for the full scrap processing: pulls it down, cuts it up and load it
- Safety environment: no more injuries
- Works in all weather conditions (from -20°C to +50°C)
- Works in toxic conditions, works overhead and below water
- No specific ground required
- Improve the return on investment of your excavator
- Optimization of your excavator
- Easy to be fitted on all excavators
- Multi tasks tool for demolition and scrap works

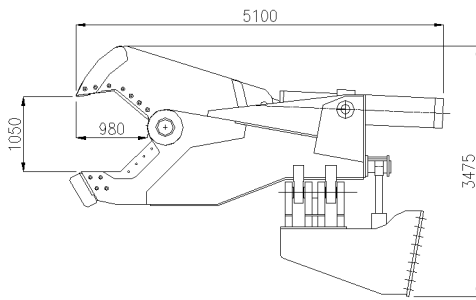

**Total weight** 14 000 kg

**Overall length** 5 100 mm

**Jaw opening** 1050 mm

**Jaw depth** 980 mm

**Oil flow and working pressure requirements**

**Main cylinder** 320 bars

**Rotation cylinder** 60 l / min, 100 bars

**Maximum hydraulic pressure** 350 bars

**Maximum cutting force** 2194 tonnes @ 320 bars



200 mm



1000x450 mm



860x25 mm

**Cuts per minute** 3,4 @ 988 l / min

**Available with 180° rotating system or without rotating system**

**Full ram guard available on request**

**Boom fitted excavator** From 70 tonnes

**Dipper end fitted excavator** From 100 tonnes

**Fits on excavator with a connecting plate with or without quick coupler**

**Manufactured by Mobile Frag Sales Ltd – England**